

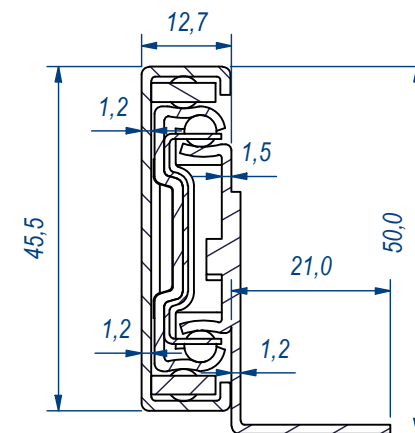

SEZ. A-A

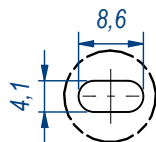

B (1:1)



REVISION HISTORY			
REV	DESCRIPTION	APPROVED BY	DATE
1	Holes diameter from 6,1 to 4,5 (16-02)	F.Dino	29/09/2016
2	Eliminated slotted hole (17-3)	F.Dino	30/10/2017
3	Added slotted hole (18-27)	F.Dino	10/05/2019

DESIGNED BY F.Dino	CHECKED AND APPROVED BY L. Paleari	REVISION	DATE 30/10/2017	CODE 44550
		GENERAL TOLLERANCE SS-ISO-2768-1M	UNIT mm	SCALE 1 of 2
		DESCRIPTION	MATERIAL Cold rolled steel	
DEVICE		PAIR WEIGHT 2,272 Kg	02C	

Property of RAM Industrie.
Without its written authorization the present drawing shall neither be used for construction anyway, communicated to third parties, nor reproduced.

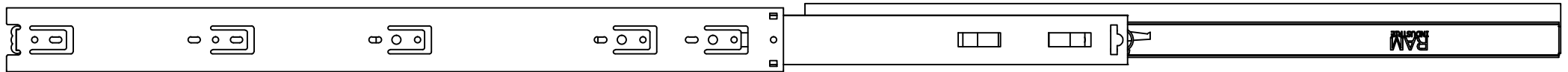

1100,0

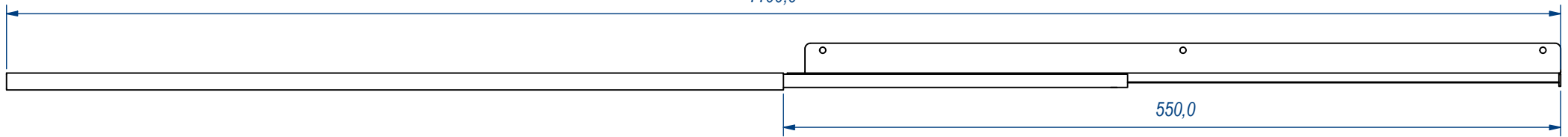

550,0

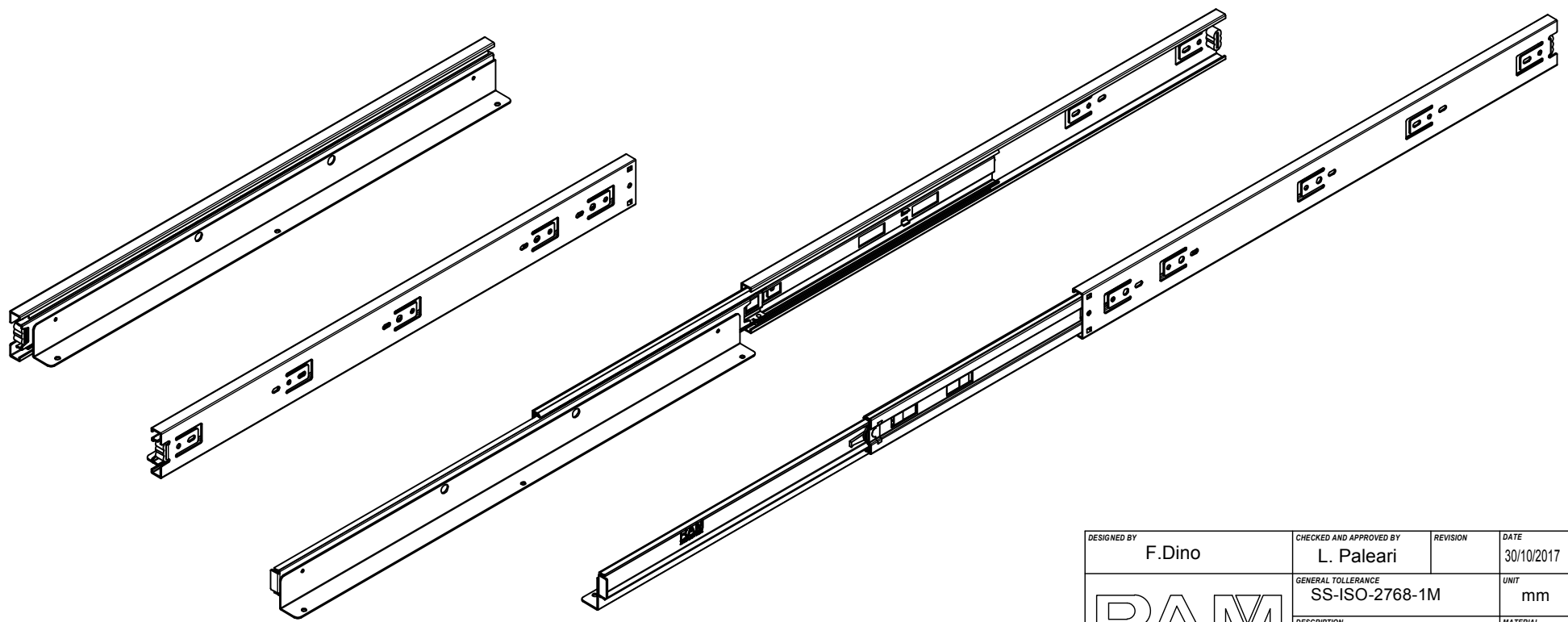
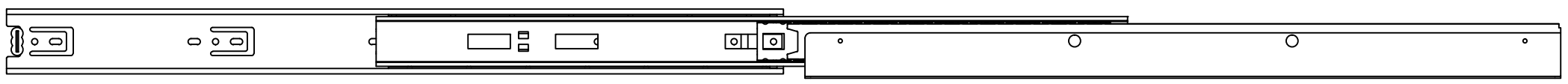

REVISION HISTORY			
REV	DESCRIPTION	APPROVED BY	DATE
1	Holes diameter from 6,1 to 4,5 (16-02)	F.Dino	29/09/2016
2	Eliminated slotted hole (17-3)	F.Dino	30/10/2017
3	Added slotted hole (18-27)	F.Dino	10/05/2019

DESIGNED BY F.Dino	CHECKED AND APPROVED BY L. Paleari	REVISION	DATE 30/10/2017	CODE 44550
		GENERAL TOLLERANCE SS-ISO-2768-1M	UNIT mm	SCALE SHEET 2 of 2
		DESCRIPTION	MATERIAL Cold rolled steel	
DEVICE		PAIR WEIGHT 2,272 Kg	02C	

Property of RAM Industrie.
Without its written authorization the present drawing shall neither be used for construction anyway, communicated to third parties, nor reproduced.