

SEZ. A-A

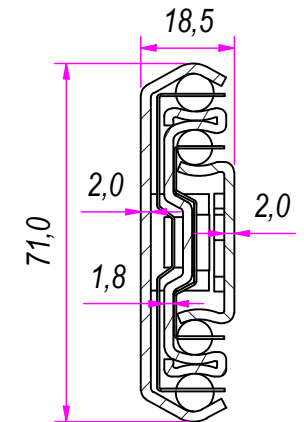

DESIGNED BY F. Dino	CHECKED AND APPROVED BY L. Paleari	GENERAL TOLERANCE SS-ISO-2768-1M	DATE 19/06/2017	CODE 73500
PACKAGING Carton 5 sets/Packed R+R			UNIT mm	SHEET 1 of 2
DESCRIPTION Cold rolled steel			MATERIAL	
DEVICE			PAIR WEIGHT 3,934 Kg	10C

**RAM**  
**INDUSTRIE**

Guide per cassetti; guide telescopiche		Coulisses à billes; coulisse télescopique		REVISION HISTORY	
Drawer slide; telescopic ball bearing slide		Guías para cajones; guía teleópica		REV	DESCRIPTION
Kugelführung; Teleskopschienen				DATE	
				1a	Modified distance between holes (19-16)
				21/10/2019	

Property of RAM Industrie.  
Without its written authorization the present drawing shall neither be used for construction anyway, communicated to third parties, nor reproduced.

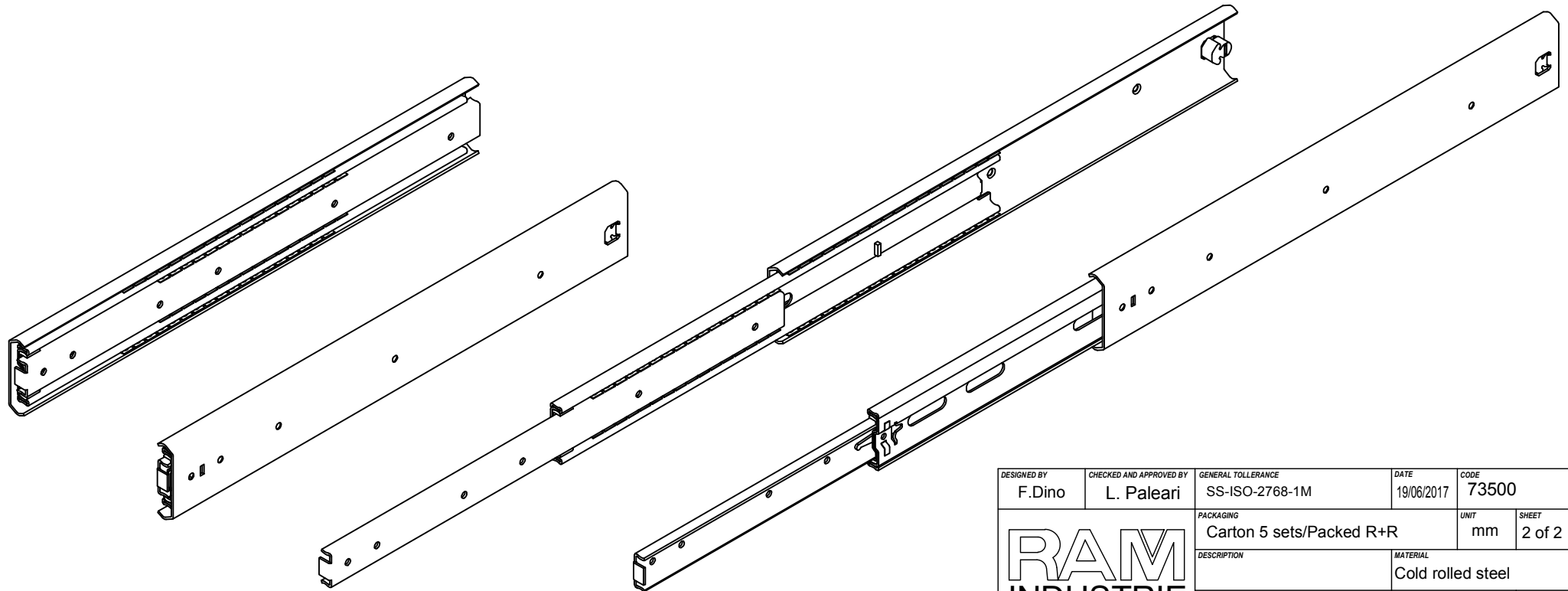
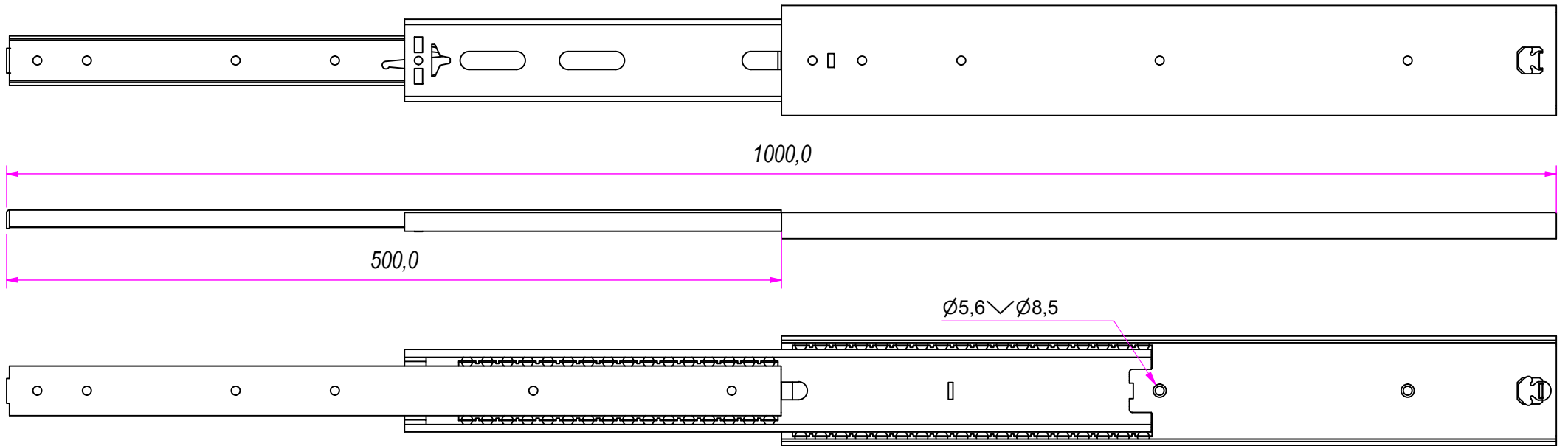

Guide per cassetti; guide telescopiche	Coulisses à billes; coulisse télescopique	REVISION HISTORY	
Drawer slide; telescopic ball bearing slide	Guías para cajones; guía teleópica	REV	DESCRIPTION
Kugelführung; Teleskopschienen		1a	Modified distance between holes (19-16)
			DATE
			21/10/2019

DESIGNED BY F. Dino	CHECKED AND APPROVED BY L. Paleari	GENERAL TOLERANCE SS-ISO-2768-1M	DATE 19/06/2017	CODE 73500
PACKAGING Carton 5 sets/Packed R+R			UNIT mm	SHEET 2 of 2
DESCRIPTION			MATERIAL Cold rolled steel	
DEVICE			PAIR WEIGHT 3,934 Kg	10C

**RAM**  
**INDUSTRIE**

Property of RAM Industrie.  
Without its written authorization the present drawing shall neither be used for construction anyway, communicated to third parties, nor reproduced.