

SEZ. A-A

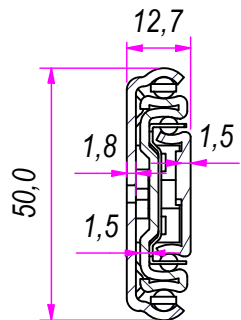

B (1:1)

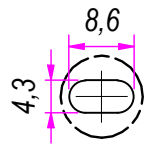

C (1:1)

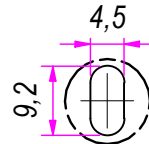

DESIGNED BY F.Dino	CHECKED AND APPROVED BY L. Paleari	GENERAL TOLERANCE SS-ISO-2768-1M	DATE 18/11/2020	CODE LE51450
PACKAGING 10 Carton/Packed R+L			UNIT mm	SHEET 1 of 2
DESCRIPTION Lock-in & lock-out			MATERIAL Cold rolled steel	
			PAIR WEIGHT 1,888 Kg	02C

**RAM**  
**INDUSTRIE**

REVISION HISTORY		REV	DESCRIPTION	DATE
Guide per cassetti; guide telescopiche	Coulisses à billes; coulisse télescopique	1a		18/11/2020
Drawer slide; telescopic ball bearing slide	Guías para cajones; guía teleópica			
Kugelführung; Teleskopschienen				

Property of RAM Industrie.  
Without its written authorization the present drawing shall neither be used for construction anyway, communicated to third parties, nor reproduced.

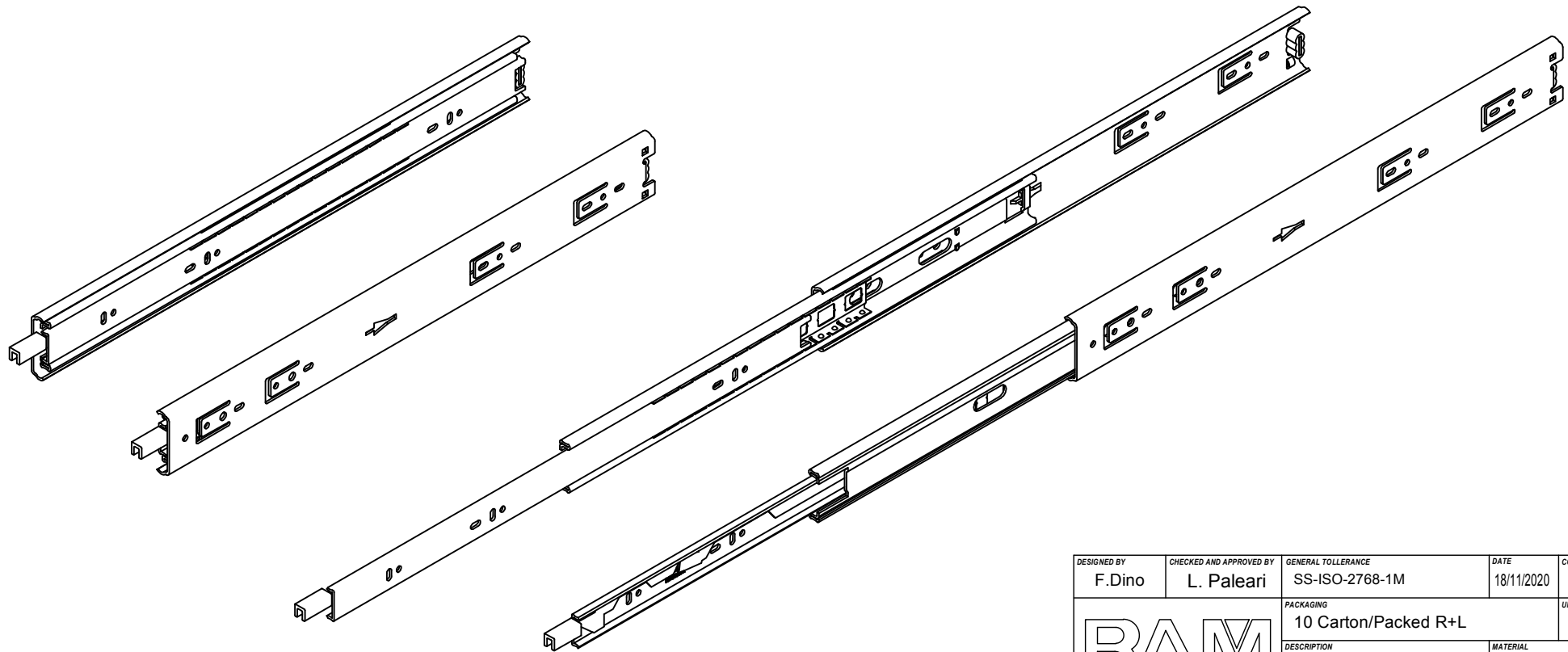
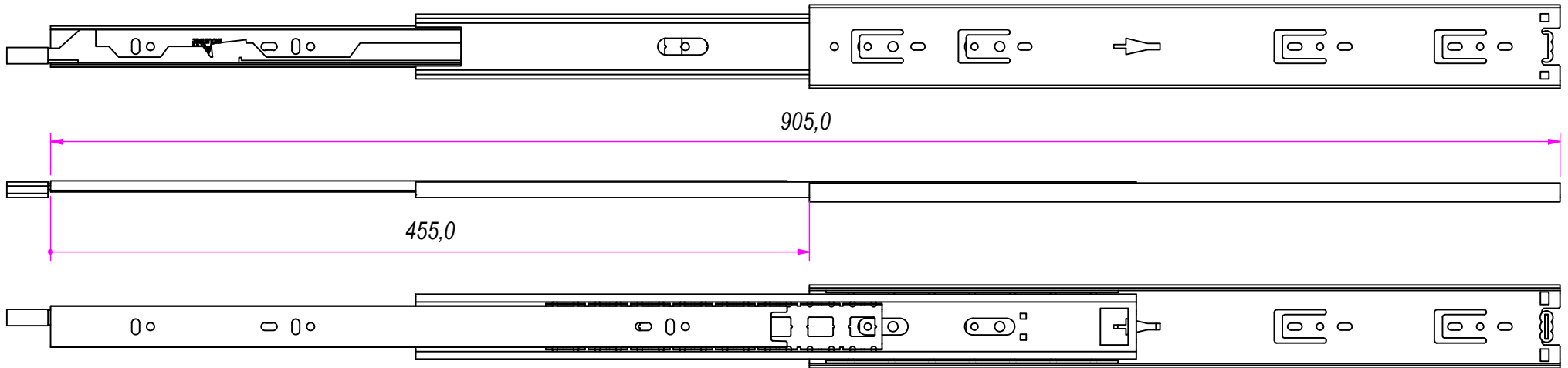

Guide per cassetti; guide telescopiche  
 Drawer slide; telescopic ball bearing slide  
 Kugelführung; Teleskopschienen

Coulisses à billes; coulisse télescopique  
 Guías para cajones; guía teleópica

REVISION HISTORY	
REV	DESCRIPTION
1a	

DATE  
18/11/2020

DESIGNED BY F. Dino	CHECKED AND APPROVED BY L. Paleari	GENERAL TOLERANCE SS-ISO-2768-1M	DATE 18/11/2020	CODE LE51450
PACKAGING 10 Carton/Packed R+L			UNIT mm	SHEET 2 of 2
DESCRIPTION Lock-in & lock-out			MATERIAL Cold rolled steel	
			PAIR WEIGHT 1,888 Kg	02C

**RAM**  
INDUSTRIE

Property of RAM Industrie.  
 Without its written authorization the present drawing shall neither be used for construction anyway, communicated to third parties, nor reproduced.