

500,0

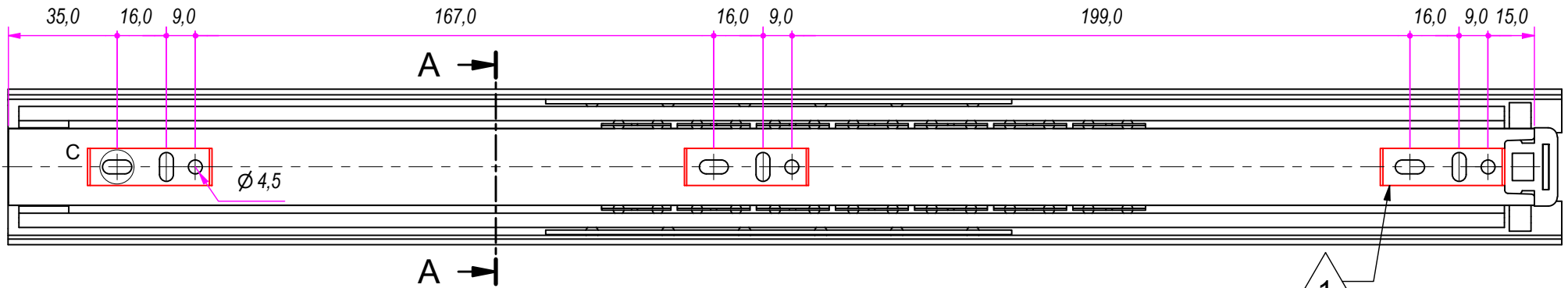

SEZ. A-A

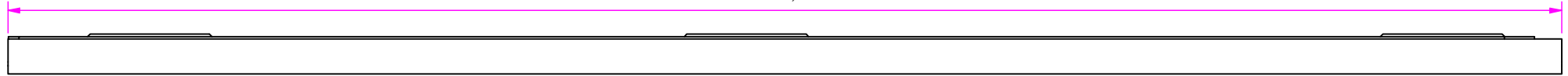
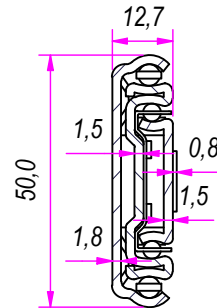

B (1:1)

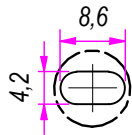

C (1:1)

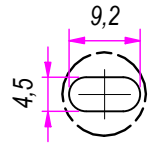

REVISION HISTORY

REV	DESCRIPTION	APPROVED BY	DATE
1	Raising the holes	F.Dino	31/08/2017

DESIGNED BY F.Dino	CHECKED AND APPROVED BY L. Paleari	REVISION	DATE 03/10/2016	CODE SE51500
		GENERAL TOLLERANCE SS-ISO-2768-1M	UNIT mm	SCALE SHEET 1 of 2
		DESCRIPTION Extra travel	MATERIAL Cold rolled steel	
DEVICE		PAIR WEIGHT 2,028 Kg	02C	

Property of RAM Industrie.
Without its written authorization the present drawing shall neither be used for construction anyway, communicated to third parties, nor reproduced.

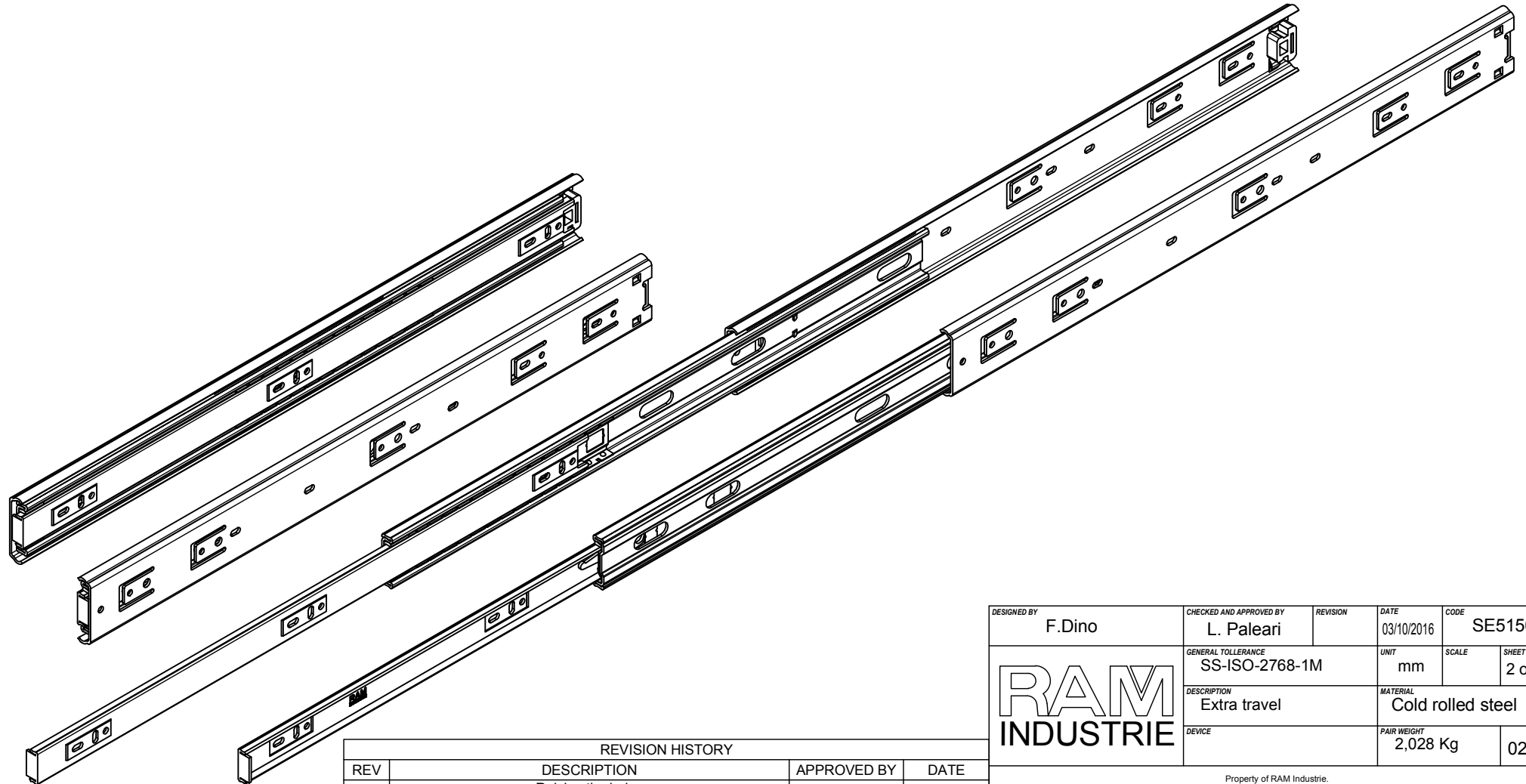
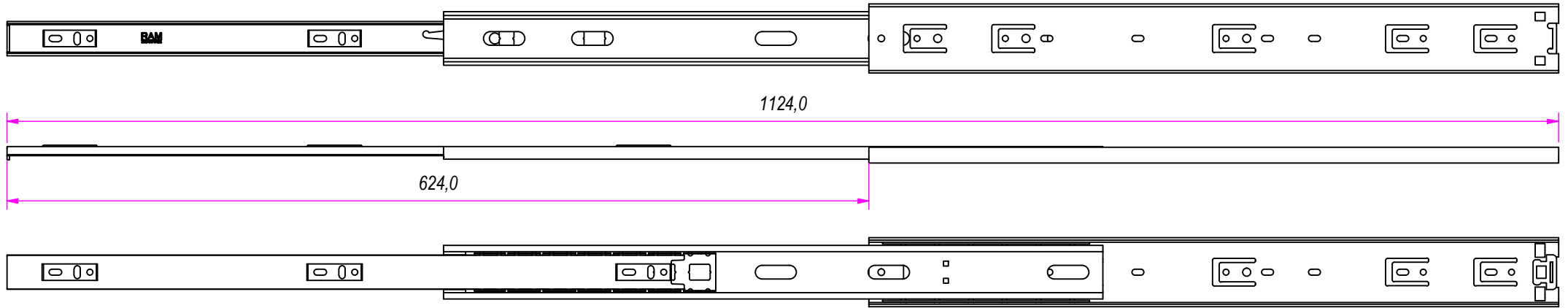

REVISION HISTORY			
REV	DESCRIPTION	APPROVED BY	DATE
1	Raising the holes	F.Dino	31/08/2017

DESIGNED BY F.Dino	CHECKED AND APPROVED BY L. Paleari	REVISION	DATE 03/10/2016	CODE SE51500
		GENERAL TOLLERANCE SS-ISO-2768-1M	UNIT mm	SCALE SHEET 2 of 2
		DESCRIPTION Extra travel	MATERIAL Cold rolled steel	
DEVICE		PAIR WEIGHT 2,028 Kg	02C	

Property of RAM Industrie.
Without its written authorization the present drawing shall neither be used for construction anyway, communicated to third parties, nor reproduced.