

B (1:1)

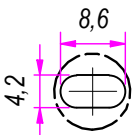

C (1:1)

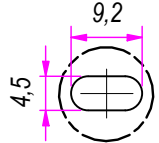

SEZ. A-A

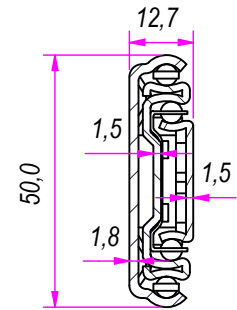

REVISION HISTORY			
REV	DESCRIPTION	APPROVED BY	DATE
1	Moved hole from 9 to 15 mm (18-16)	F.Dino	01/10/2018

DESIGNED BY F.Dino	CHECKED AND APPROVED BY L. Paleari	REVISION	DATE 03/10/2016	CODE SH511100
		GENERAL TOLLERANCE SS-ISO-2768-1M	UNIT mm	SCALE 1 of 2
		DESCRIPTION	MATERIAL Cold rolled steel	
DEVICE		PAIR WEIGHT 4,632 Kg	02C	
<small>Property of RAM Industrie. Without its written authorization the present drawing shall neither be used for construction anyway, communicated to third parties, nor reproduced.</small>				

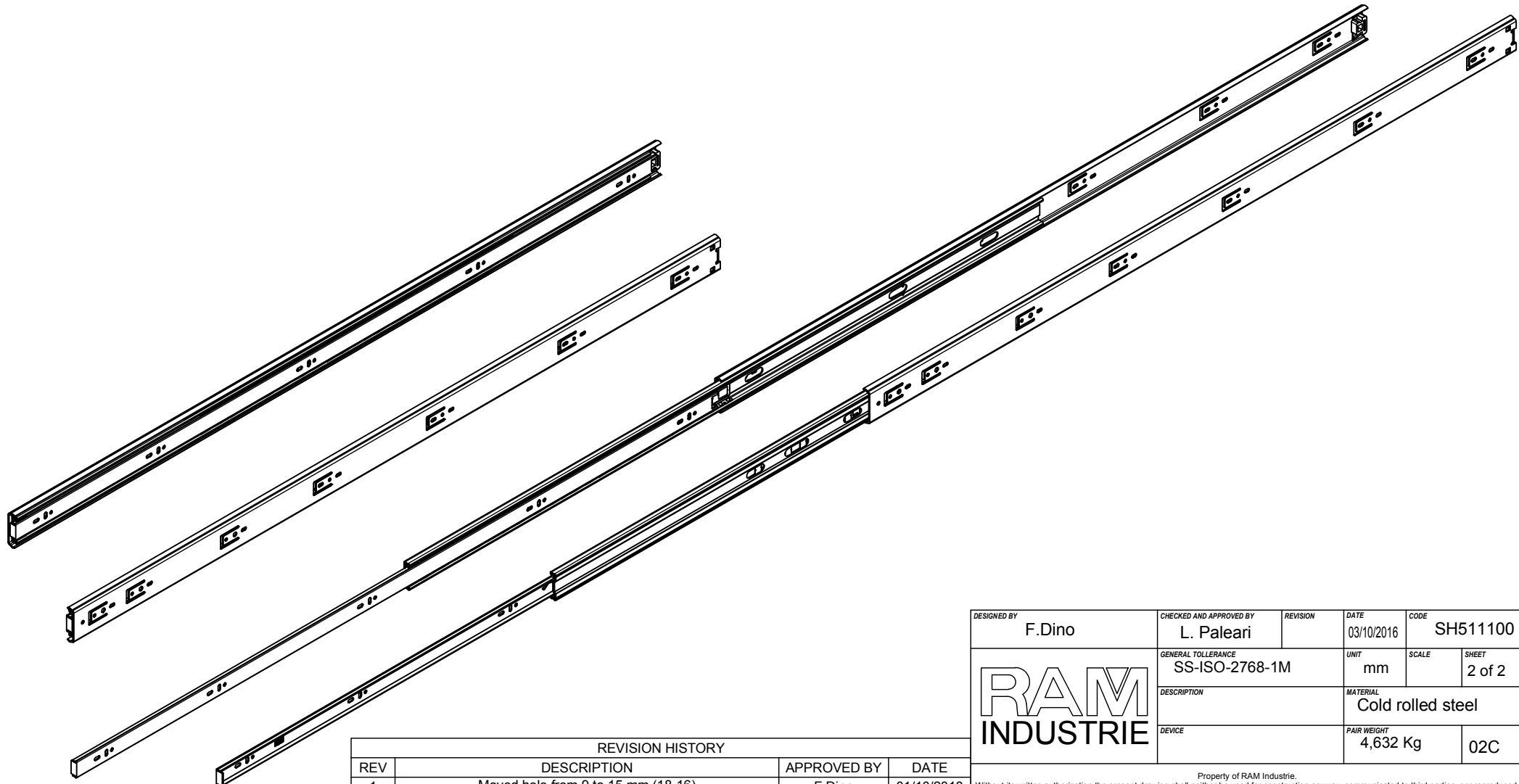
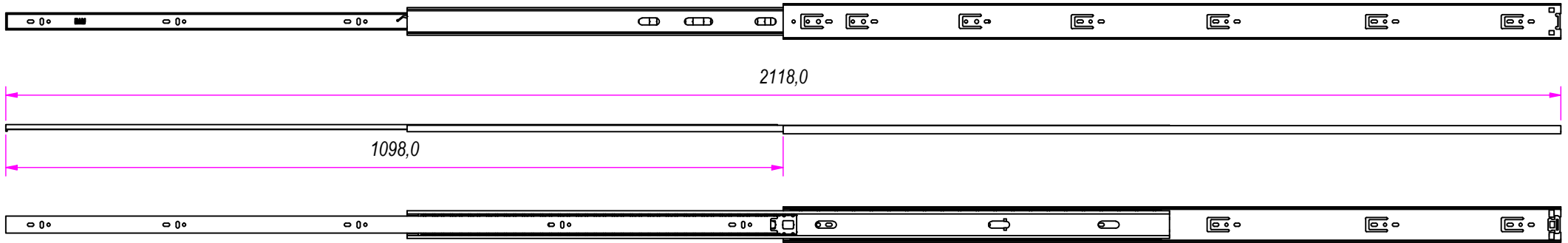

REVISION HISTORY			
REV	DESCRIPTION	APPROVED BY	DATE
1	Moved hole from 9 to 15 mm (18-16)	F.Dino	01/10/2018

DESIGNED BY F.Dino	CHECKED AND APPROVED BY L. Paleari	REVISION	DATE 03/10/2016	CODE SH511100
		GENERAL TOLLERANCE SS-ISO-2768-1M	UNIT mm	SCALE 2 of 2
		DESCRIPTION	MATERIAL Cold rolled steel	
DEVICE		PAIR WEIGHT 4,632 Kg	02C	

Property of RAM Industrie.
Without its written authorization the present drawing shall neither be used for construction anyway, communicated to third parties, nor reproduced.